

# MANUAL RETURN LOSS MEASUREMENTS

Sam Wetterlin

[swetterlin@comcast.net](mailto:swetterlin@comcast.net)

10/5/08

This paper describes the procedure for using a reflection bridge (a/k/a “return loss bridge”) to manually measure return loss (easily converted to SWR if desired). “Manual” means we don’t have all the automation of a vector network analyzer, and we also can’t utilize elaborate calibration to improve accuracy.

## The measurement procedure

The basic setup is shown in Figure 1.

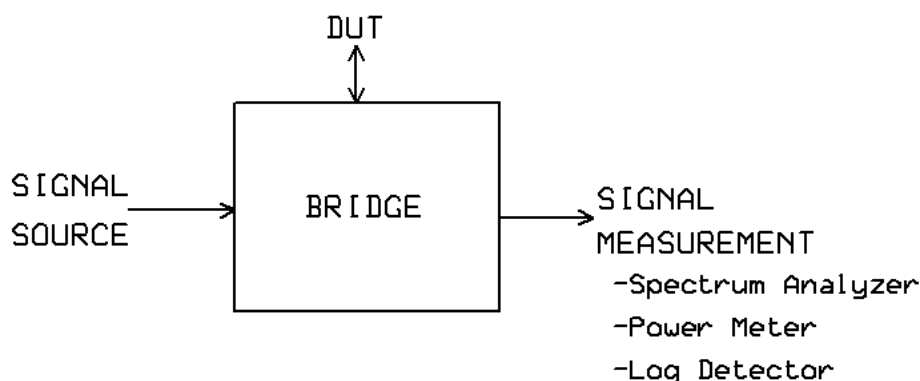

**Figure 1—Basic Setup**  
“DUT” is the device under test; it receives a signal and returns a reflection.

We need a signal source, whose frequency we must set manually, and we need a way to measure the output level in dbm, which we will have to record manually. It is possible to get some automation by using a sweep generator; more on this later.

The bridge routes the input signal to the DUT and outputs a signal proportional to the reflection received from the DUT. The bridge itself can take various forms. One such bridge is described later. For the moment, suffice it to say that it is not difficult to build a reflection bridge which can isolate the reflection well enough to measure return losses in the range 0-30 db with as much accuracy as we generally need.

We use a type of calibration called “reference calibration”, whereby we establish a reference output level representing zero return loss, attach the DUT, and compare the DUT reflection level to the reference level. For example, if the reference level is -2 dbm, and the output with the DUT attached is -23 dbm, the return loss is 21 dbm. The reference is established by using two measurement standards: an open and a short. The open is a coax connector whose backside has nothing attached. The short is a connector whose backside is directly shorted by a metal strip or disc connecting the center pin to the body of the connector. Of course, we can get an open circuit by not attaching anything to the output connector, but at higher frequencies the short transmission line represented by the open connector has some effect, and we want the distance to

the actual point of the open circuit to be about the same as the distance to the actual short. Below a couple hundred MHz, we probably don't actually need to attach an open connector.

To get a reference level representing zero return loss, we can just measure the output with the open standard attached. An open circuit has a return loss of zero. A short circuit also has a return loss of zero (meaning 100% reflection), but the phase of the reflection is 180 degrees different between an open and a short. Because we are not measuring phase (return loss is a scalar quantity), the output with the open and short attached should look identical, in theory. In practice, there will generally be some difference between the open and short reflection outputs, though it is often less than 0.5 db. To reduce error, we can use as the reference level the average between the open and short outputs. But if we have verified that the open/short difference is less than 1 db, this averaging will give us a reference only 0.5 db from what we would get using the open reflection as the reference level, so the averaging may not be worth the bother.

### **What are we measuring?**

Return loss is derived from the voltage of the signal reflected by a device under test (DUT). If we know the voltage of the signal sent to the DUT and the voltage of the reflection, the reflection coefficient is the ratio of the reflected signal to the incident signal:

$$\text{Reflection Coefficient} = \Gamma = \text{Reflected Voltage/Incident Voltage}$$

That ratio is what we will use to measure the reflection coefficient. Another formula, useful when you know the impedance of the DUT, is as follows:

$$\text{Reflection Coefficient} = \Gamma = \frac{Z - Z_0}{Z + Z_0}$$

Z=DUT impedance;

Z<sub>0</sub>=Reference Impedance (here, 50 ohms)

We will always use a reference impedance of 50 ohms here.

Return loss is the magnitude of that reflection coefficient expressed in decibels as a non-negative number:

$$\text{Return Loss} = -20 * \text{Log}(|\Gamma|)$$

(Since  $|\Gamma| \leq 1$ , return loss will be non-negative)

In our case, the conversion into decibels is done automatically by the instrument measuring the bridge output, as that instrument will measure in dbm.

Those are the technical formulas, but what does a given level of return loss actually mean? Return loss can be translated into SWR, or into the percent of power reflected by the DUT, or, roughly, into impedance. Table 1 shows those values for various levels of return loss.

Return Loss	Reflect Coef. Mag.	SWR	% Power Reflected	R>50 ohms	R<50 ohms
0	1.000	INF	100.00	INF	0.0
1	0.891	17.4	79.43	869.5	2.9
2	0.794	8.72	63.10	436.2	5.7
3	0.708	5.85	50.12	292.4	8.5
4	0.631	4.42	39.81	221.0	11.3
5	0.562	3.57	31.62	178.5	14.0
6	0.501	3.01	25.12	150.5	16.6
7	0.447	2.61	19.95	130.7	19.1
8	0.398	2.32	15.85	116.1	21.5
9	0.355	2.10	12.59	105.0	23.8
10	0.316	1.92	10.00	96.2	26.0
15	0.178	1.43	3.16	71.6	34.9
20	0.100	1.22	1.00	61.1	40.9
25	0.056	1.12	0.32	56.0	44.7
30	0.032	1.07	0.10	53.3	46.9
35	0.018	1.04	0.03	51.8	48.3
40	0.010	1.02	0.01	51.0	49.0
50	0.003	1.01	0.00	50.3	49.7
60	0.001	1.00	0.00	50.1	49.9

**Table 1—Translating return loss to reflection coefficient, SWR, percentage of power reflected, and equivalent resistance, one greater than and one less than 50 ohms.**

The correspondence of return loss and impedance deserves a little more attention. Any given return loss can be generated by a variety of impedances; each such impedance generates the same magnitude of reflection coefficient, but different phases. Since return loss is a scalar quantity, it does not include the phase, so all those impedances generate the same return loss. Figure 2 shows the impedances that generate a reflection coefficient whose magnitude (denoted by  $\rho$  [rho]) is 0.33, corresponding to a return loss of 9.6 db.

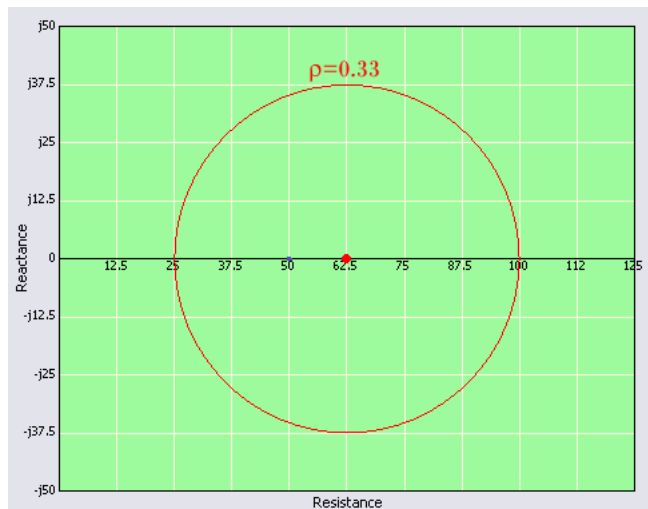

**Figure 2—Impedances which generate a reflection coefficient with magnitude of 0.33 (return loss of 9.6 db).**

There are two pure resistance values which create any finite return loss. As shown in Figure 2, if the lower one is  $50/N$  ( $N=2$  in this case), then the higher one is  $50*N$ . As the reflection coefficient decreases (return loss increases), the circle gets smaller and smaller and its center moves closer and closer to 50 ohms. Therefore, return loss can be thought of as a measure of how close the impedance is to 50 ohms.

**How much accuracy do we need?**

As a preliminary matter, we should explore how much accuracy we need when measuring return loss. One way of looking at return loss is that it measures the amount of power reflected by the DUT. Generally, if the DUT has return loss of 20 db or better (higher), it is reflecting so little power (1% of the incident power) that it does not really matter exactly how little it is. On the other hand, if a DUT reflects half or more of the power reaching it (return loss of 0-3 db), we may just consider it to be unacceptable, without having to know exactly how much it reflects. So if we know the return loss is higher than 20 db or lower than 3 db, that may be all we need to know. And even for values in the 3-20 db range, errors of several db may not be meaningful.

If we look at return loss as an indirect measure of impedance, high return losses mean the DUT has an impedance close to 50 ohms. For example, as shown in Table 1, resistances between 46.9 and 53.3 ohms have return losses of 30 db or higher. If we consider such a DUT equal to 50 ohms, we have a possible 6% error. For many purposes, that is all the accuracy we need, so in many cases verifying that the return loss exceeds 30 db is all we need to know, and there is no point to trying to determine whether it is actually 40 db, 50 db, or infinity. Return losses that are near zero indicate impedances that are far from 50 ohms. For example, resistances of 3 ohms and 870 ohms have return losses of 1 db. Getting the return loss exactly right in that situation does not help us much, since we are left with two wildly different resistances that may have that return loss, and we have no way to choose which is correct, since we lack phase information. In fact, as noted earlier, the impedance may have a reactive component as well, and there is an entire circle on the impedance plane of possible DUTs with a return loss of 1. When you look at return loss as a measure of impedance, it tells you whether you are close or far from 50 ohms; if you are close you have a good idea what the impedance is; if you are far away you don't even know what direction you are from 50 ohms, so you know you have a problem, but you're not sure exactly what it is.

Because return loss is a scalar value, we cannot determine the exact impedance even if we knew the exact return loss. Phase information would be required. Our manual use of the bridge provides only scalar information, and is effectively a "scalar network analyzer", as opposed to the fancier "vector network analyzers", which provide phase information (magnitude combined with phase = vector). The absence of phase information in return loss generally makes it pointless to try to determine return loss precisely.

### **The Parallel Line Bridge**

Appendices A and B show a bridge which performs very well for manual measurements from 1 MHz to 500 MHz. In addition, it provides the ability to supply the DUT with a DC bias without interfering with the measurement, though we won't discuss that feature here. It is a standard bridge arrangement, but with an extra grounded line added alongside the balun to provide better balance. Because the coax used for the balun and this extra line are parallel, I refer to this bridge as the Parallel Line Bridge. The coax used is a relatively expensive type (UT-56) available from [amawave.com](http://amawave.com). Similar UT-47 coax is more readily available, but still expensive. Though those coax types are expensive, only a few inches of coax are required. Decent performance can probably be obtained with readily available RG-178 or RG-316, by stripping off the Teflon jacket to allow the coax to fit through the ferrites, or using ferrites with larger holes. The other unusual thing about this bridge is that the resistors in the arms of the bridge are 62 ohms, rather than 50 ohms. This is to compensate for the leakage of common-mode signal through the coax and the wire line. That leakage is opposed by the ferrites, which create inductance and resistance (through ferrite losses). If the ferrite effect were perfectly resistive and equal in both the coax and the parallel wire, it could be perfectly compensated by adjusting the resistances in the arms of the bridge.

The ferrites used in the bridge are available at [amidoncorp.com](http://amidoncorp.com); some are available at lower cost at [kitsandparts.com](http://kitsandparts.com).

Figure 3 shows the performance of the Parallel Line Bridge over a wide frequency range. Both directivity and open/short are graphed; they will be discussed momentarily.

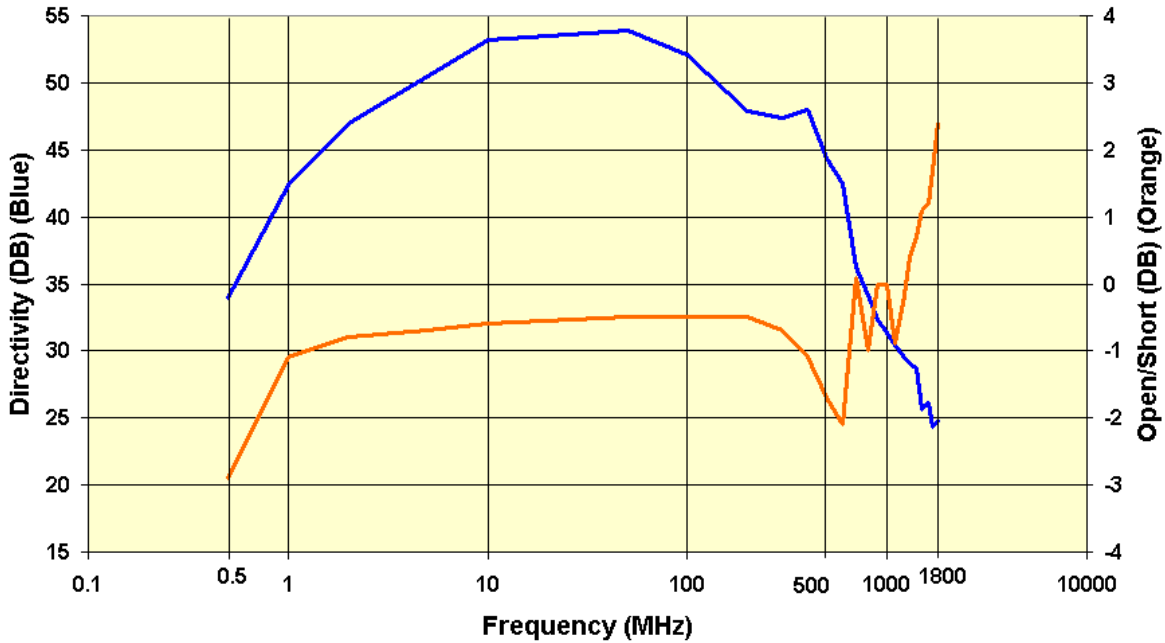

**Figure 3—Parallel Line Bridge Wideband Performance**

Figure 4 shows the performance over the more limited range where the Parallel Line Bridge is well suited for manual measurements.

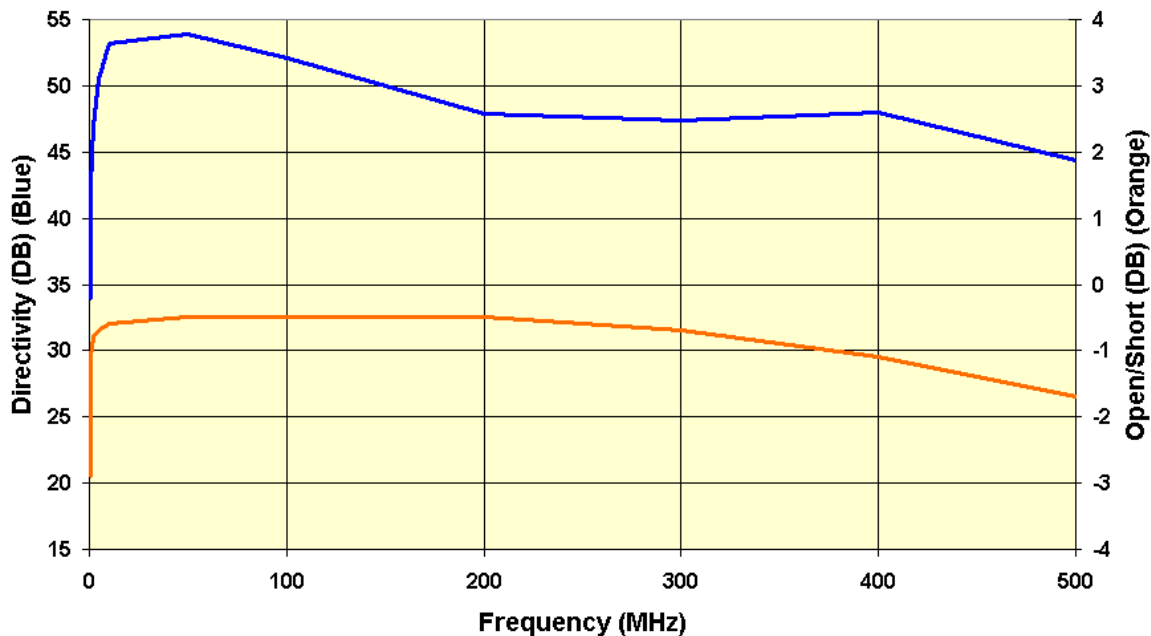
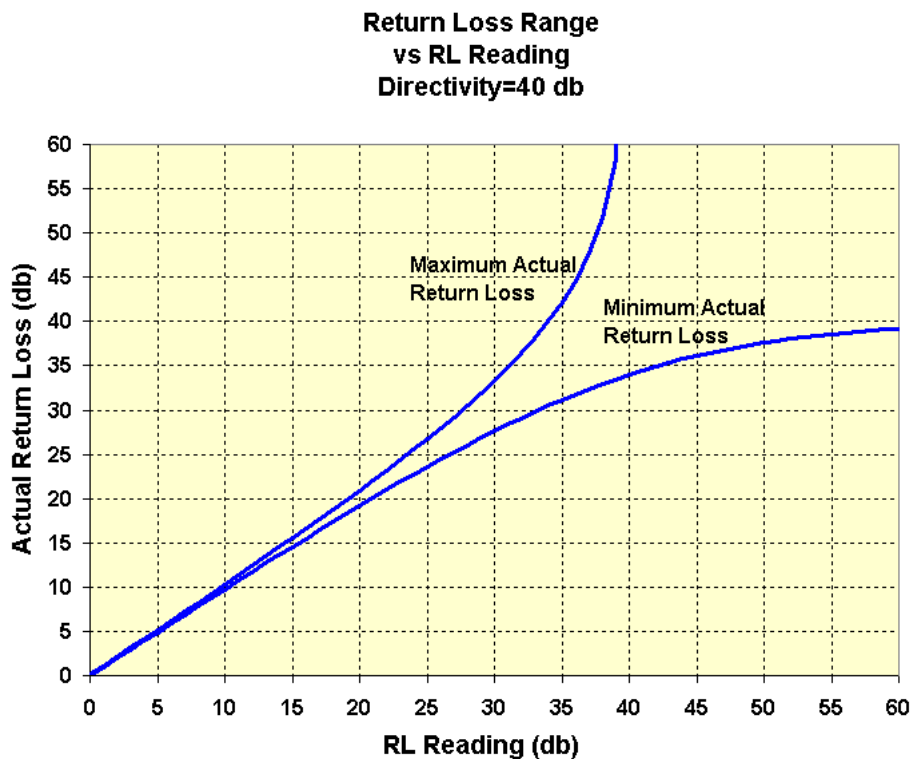

**Figure 4—Parallel Line Bridge Performance For Manual Measurements**

Let's first consider directivity. Figure 4 shows that the bridge has directivity better than 45 db from near 1 MHz to 400 MHz, and maintains directivity better than 40 db to 500 MHz. Directivity is the amount of reflection measured for a 50-ohm DUT (but with the negative sign dropped). In that case, there is no actual reflection, so the directivity represents a bogus signal which is being added to the actual reflection. It therefore imposes a fundamental limit on our measurement accuracy, especially when the actual reflection is not large enough to swamp the bogus signal.

If we have directivity of 40 db, then the bogus signal is 40 db below the signal sent to the DUT. If the actual return loss is also 40 db, then the voltage levels of the reflection and the bogus signal are equal. Depending on phase, the combined voltage could be as high as double that of the actual reflection, or as low as zero. That means our measurement may come out anywhere from 34 db (i.e. 6 db higher than actual, representing doubling of the voltage) to infinity (representing complete canceling of the reflection by the bogus signal). On the other hand, if the actual reflection is much stronger than the bogus signal, as with a return loss of 10 db, then the possible effects of the bogus signal are much diminished.

Figure 5 shows the relationship between our return loss reading and the possible range of values of the actual return loss, assuming bridge directivity of 40 db.



**Figure 5—Possible actual return loss values for a given return loss reading, for directivity of 40 db, including only the error arising from imperfect directivity.**

Figure 5 shows that we can determine return losses with reasonable accuracy if they are below 30 db. Once the return loss reading rises to 40 db and higher, we can say with confidence that the return loss is at least some minimum value (34 db for a reading of 40 db), but there is no limit to what the maximum might be. That infinite range may seem like unacceptable error, but remember that for large return losses we frequently only need to know that the return loss

exceeds some threshold, without caring how far it exceeds the threshold. If we get a very large reading, like 60 db, we can be sure the true return loss is at least 40 db, which may be all we are looking for. Large return losses means the DUT impedance is near 50 ohms, and it is often not necessary to pin down exactly how close it is.

The other performance measurement shown in Figures 3 and 4 is the relative level of the measurements for open and shorted DUTs. This is referred to as “open/short” because it represents the ratio of the measured reflection with open and shorted DUTS, though we actually calculate it by subtracting the short output from the open output, since we are operating in dbm. Ideally, the open and short should have reflections of equal magnitude (and opposite phase), so the open/short would be zero. Figure 4 showed that the magnitude of the open/short for the Parallel Line Bridge is generally less than 1, though between 400 and 500 MHz it rises to 1.7.

If we use the average of those two to establish the reference level for zero return loss, then there is a possible error of half their difference, because for large impedances it would be more correct to use the open reflection level as the reference, and for small impedances it would be more correct to use the short reflection level. Since we don't know the actual impedance, we are not sure which reference to use. By using the average, we get a possible error equal to half the difference between the open and short levels. In our case, that error is generally less than 0.5 db, but reaches 0.85 db at 500 MHz.

Large differences between the open and short may indicate poor return loss at the DUT port of the bridge. This would mean that part of the reflection received from the DUT would be re-reflected, causing measurement error. This error is relatively small for open/short magnitudes under 1, but for higher values with very low return loss DUTs, it might reach 1 db (because they reflect most of the re-reflection, perhaps doubling the error).

Finally, there is some error in the actual measurement of the bridge output. This error is reduced to some extent by our reference calibration. For example, if the measurement device is consistently 1 db low, both our reference level and DUT reflection levels will be low by that amount, so when we calculate the difference between the two levels (i.e. the measured return loss), the error will disappear. Particularly when the two measurements are very close, there is very likely the same error in each measurement, and there will be complete error cancellation. However, when the reference and DUT reflection levels differ by a large amount (that is, the measured return loss is large), it is possible that the error in the two measurements is different. For example, a power meter may have little error measuring a level of 0 dbm, but might have 1 db of error measuring a level of 30 db. That means that when we subtract the DUT reflection from the open reflection (in dbm), we would end up with an error of 1 db.

Altogether, let's assume that there is an additional 1.5 db of error in each of the lines shown in Figure 5. Figure 6 shows that increased error.

**Return Loss vs RL Reading  
Directivity and Other Error  
Directivity=40 db**

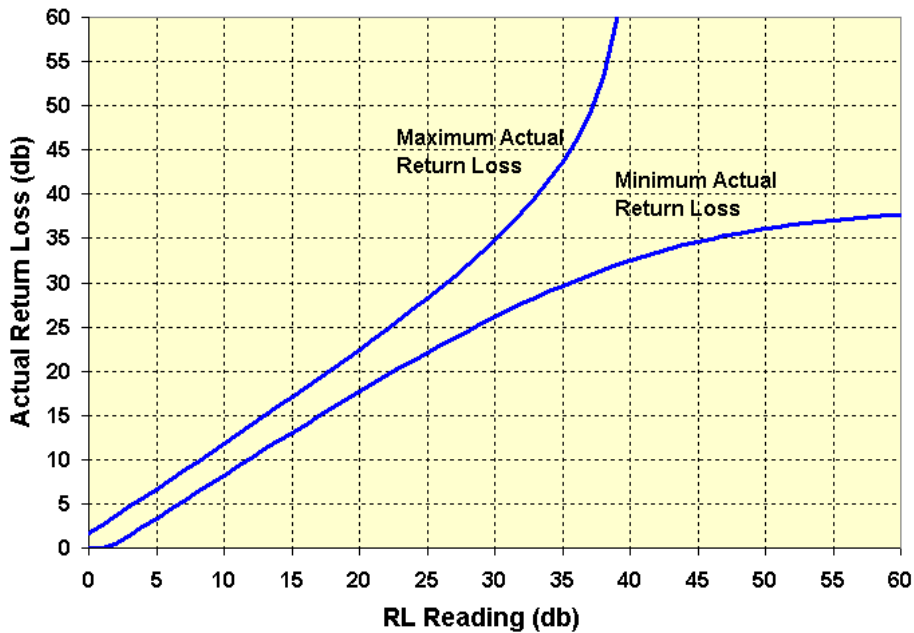
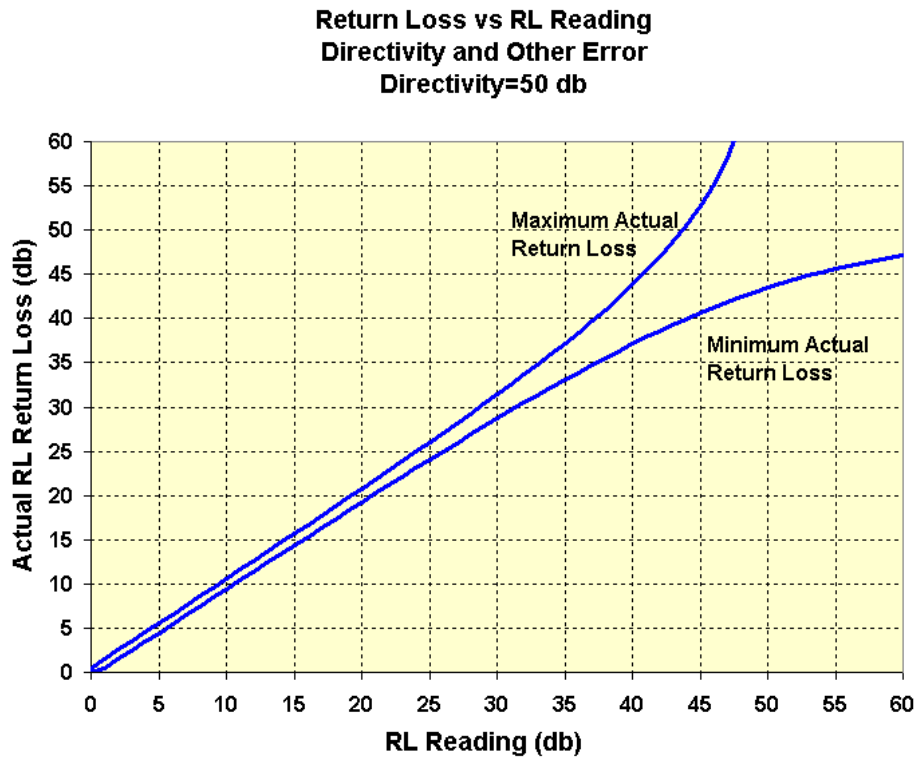

**Figure 6—Total error for directivity=40 db  
Allowing 1.5 db for “other” error**

The total error for directivity of 40 db shown in Figure 6 is acceptable for decent measurements of return losses up to 30 db. For higher return losses, a bridge with directivity of 40 db is sufficient to verify that the return loss exceeds a certain threshold. For example, a reading of 35 db verifies that the actual return loss exceeds 30 db. This accuracy is sufficient for most practical return loss measurements.

**Use of the Parallel Line Bridge from 10 MHz to 100 MHz.**

We have been talking about measurements in the 1-500 MHz range. If we restrict ourselves to 10-100 MHz, the directivity of the Parallel Line Bridge is over 50 db, and the open/short is minimal. In this case, the directivity error will be very small and, if we use an accurate measurement device, the “other” error on top of the directivity will be 0.5 db or less. This would give us the error profile shown in Figure 7.



**Figure 7—Total error for directivity=50 db**  
**Allowing 0.5 db for “other” error**

Figure 7 shows that the parallel line bridge, with an accurate output measurement, gives us outstanding accuracy for any return loss we would normally want to measure.

**Semi-Automatic Measurement**

So far, we have described a point-by-point measurement process where the DUT output is compared to the open output. With a sweep generator and spectrum analyzer, we can automate the process a bit. Even better would be to use a tracking generator with the spectrum analyzer, but I don't have one.

Figure 8 shows a scan of the return loss of a multi-stage LC filter. The sweep generator was set to sweep at its fastest rate, and the spectrum analyzer was set to sweep at a rate of 5 sec/sweep. The result is a filled-in area whose envelope is a graph of the bridge output.

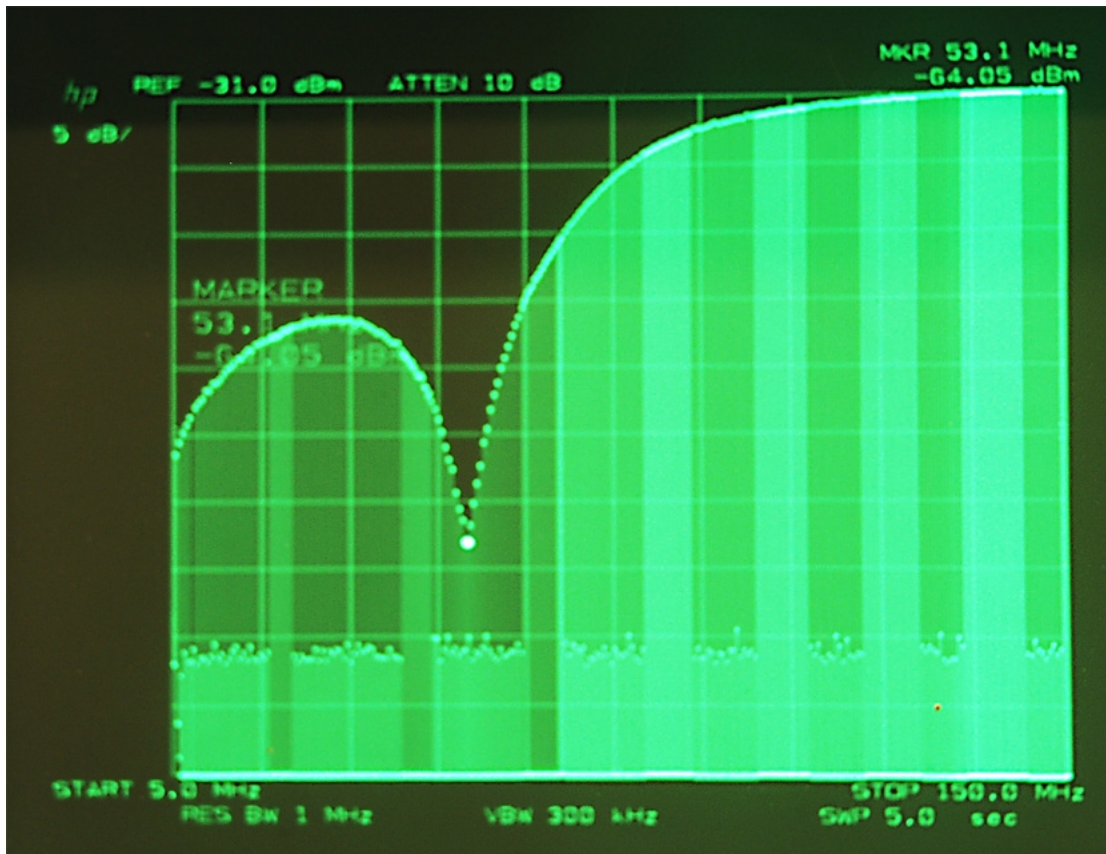

**Figure 8—Swept return loss of an LC lowpass filter. The spectrum analyzer reference level was adjusted so the bridge output with an open DUT was at the top of the grid. Return loss is the distance between the top and a point on the graph, based on 5 db per vertical division. The dip measures return loss of 33 db.**

In this case, I ignored the difference between the open and short. To be precise, I could have adjusted the reference level so the open and short outputs straddled the top line, but such precision is often not necessary. Even without precise measurements, this scan shows the location of the return loss dip (53 MHz), and also shows that there is an area of modest return loss (15-20 db) near 25 MHz. The dip is deep enough that with directivity of 50 db the true return loss could be in the range 31-35 db, per Figure 7. As a practical matter, if a filter has return loss better than 30 db, it is probably of no concern exactly what the value is.

For wider sweeps, the output level for the open will not be perfectly flat because the insertion loss of the bridge increases with frequency. That makes it harder to use the top of the grid as a reference point. For highest accuracy, it would then be necessary to save the scan of the open and display it on-screen when the DUT is scanned. There is a minor amount of confusion because the DUT graph will appear within the filled-in area of the open graph, but it is still quite easy to compare the two levels.

Instead of using a spectrum analyzer, an oscilloscope could be used, but the bridge output would first have to be converted to dbm, perhaps by a log detector like the AD8310. The log detector output would then control the Y-axis of the oscilloscope, and the signal generator sweep voltage would control the X-axis. Note that the oscilloscope would be operating at a fairly low frequency. Even a PC-based oscilloscope utilizing the sound card could be used.

## Attaching the DUT

The bridge has a female SMA connector for the DUT. A DUT with a male SMA connector can be attached directly to the bridge. Other DUTs may be attached via an adapter. In either case, a length of coax cable may also be used. Such adapters and/or cable will constitute a transmission line connecting the bridge to the DUT. An impedance at the far end of a transmission line appears as a different impedance at the beginning of the line. This is widely known for quarter-length lines, since the formula for calculating the impedance transformation is simple for that length. But it is true for other lengths as well. *The interesting thing is that the actual impedance and the transformed impedance have the same return loss, if the transmission line is 50 ohms.* That is because the same reflection occurs at the DUT with or without the cable, and all the cable does is delay the timing (phase) of the reflection returning to the bridge. That means that, in theory, the return loss measurement is not affected by any adapters or coax cable.

In reality, no adapter or coax cable has the ideal characteristic impedance. Especially for long cables and/or high frequencies, the method of attaching the DUT may alter the return loss measurement. To be safe, check the difference between an open and short attached at the end of the cable, and measure the return loss of a good 50-ohm termination at the end of the cable. Then proceed as though the bridge open/short and the bridge directivity are those values you just obtained. For example, if the termination measures 30 db return loss, then 30 db becomes your directivity, and you have to analyze the error accordingly.

This is not likely to be an issue for simple adapters or cables under 1 ft. until you exceed several hundred MHz. One way to compensate is to connect the REF load through the same adapters/coax used for the DUT. This improves directivity by maintaining symmetry.

If the cable leading from the signal source to the bridge input, or the cable leading from the bridge output to the spectrum analyzer is not high quality, or if the signal source or spectrum analyzer do not present good 50-ohm impedances, measurement accuracy may suffer. For that reason, it is a good idea to use attenuators at the bridge input and output. There are built-in attenuators of 3 db. If necessary, those can be increased or external attenuators can be used. If in doubt, measure with and without attenuators. If there is a difference and the attenuators are decent, then the measurement with the attenuators is the more accurate. However, you can't use an attenuator on the DUT output, because the attenuator effectively becomes part of the DUT and raises its return loss.

### **An Active Bridge**

With operational amplifiers it is possible to make a bridge that is extremely precise. Appendices C and D show such a bridge, that is quite simple to make. Figure 9 shows the performance of that bridge.

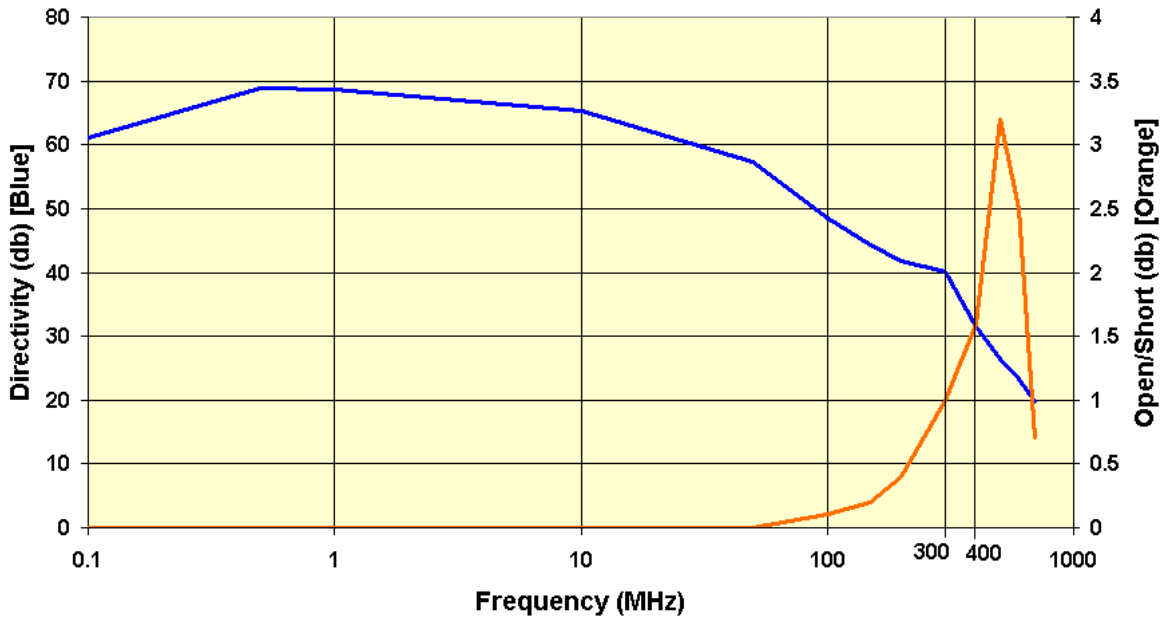

**Figure 9—Performance of Active Bridge**

The bridge of Figure 9 has at least 40 db directivity and good open/short up to 300 MHz, and in more limited ranges can achieve directivities of 50 and 60 db. Two different builds had similar performance. Let’s look at the accuracy that can be achieved in the range below 30 MHz, where directivity exceeds 60 db and the open/short is zero. Figure 10 shows the error profile, again allowing 0.5 db of error in the device used to measure the bridge output.

**Return Loss vs RL Reading  
Directivity and Other Error  
Directivity=60 db**

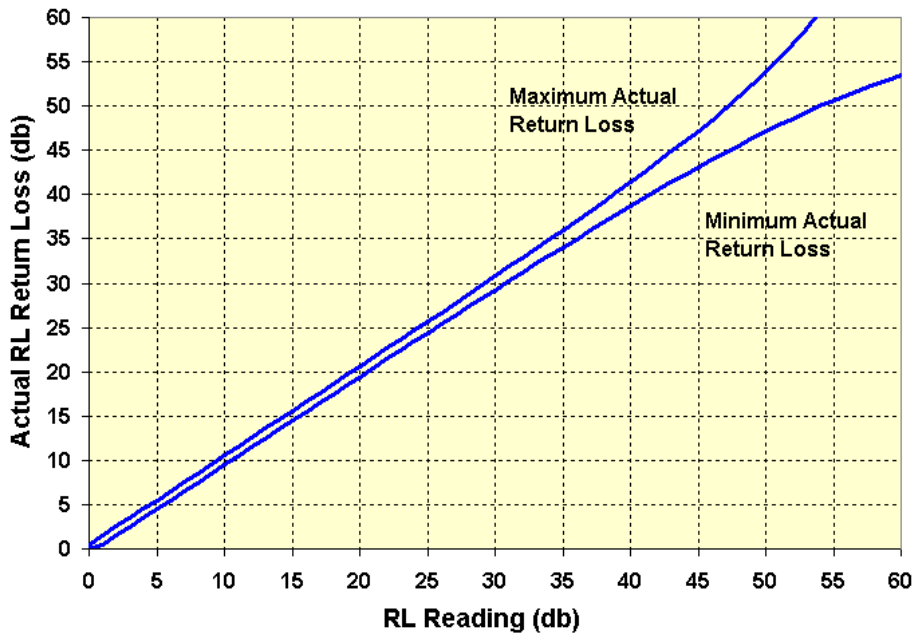

**Figure 10—Total error for directivity=60 db  
Allowing 0.5 db for “other” error**

Figure 10 shows that the return loss measurements of the active bridge up to 30 MHz are about as good as the device measuring the bridge output for return losses up to 25 db, and such measurements are quite good as high as 45 db. Note that while this bridge has a big advantage for measuring large return losses, it is only a tiny bit better than the Parallel Line Bridge for return losses of 20 and lower. However, this bridge also has excellent performance at very low frequencies, limited only by the size of coupling capacitors used. If it were built with dual +/- supplies, no coupling capacitor would be needed for the DUT port and it could be used at very low frequencies. Another advantage of this bridge is that its performance depends on fairly well-controlled op amp characteristics, rather than ferrite characteristics and winding technique. This means that the achievement of directivity of 60 db with near-zero open/short is repeatable.

### **Conclusion**

We have examined techniques for making and using reflection bridges to measure return losses with as much accuracy as we would normally need. For use in the world of transmitters and antennas, those return loss values can readily be converted to SWR or percent of reflected power. In other circuitry these bridges can verify that amplifiers or filters have acceptable return loss, and identify problem areas. High return losses indicate an impedance near 50-ohms; lower return losses can represent a wide range of impedances (in fact, a circle of impedances) and cannot be converted to a specific impedance value, because of the lack of phase information. Some specific uses of return loss measurements will be covered in a separate paper, as will a presentation of other bridge designs.

# Appendix A—The “Parallel Line” Bridge Schematic

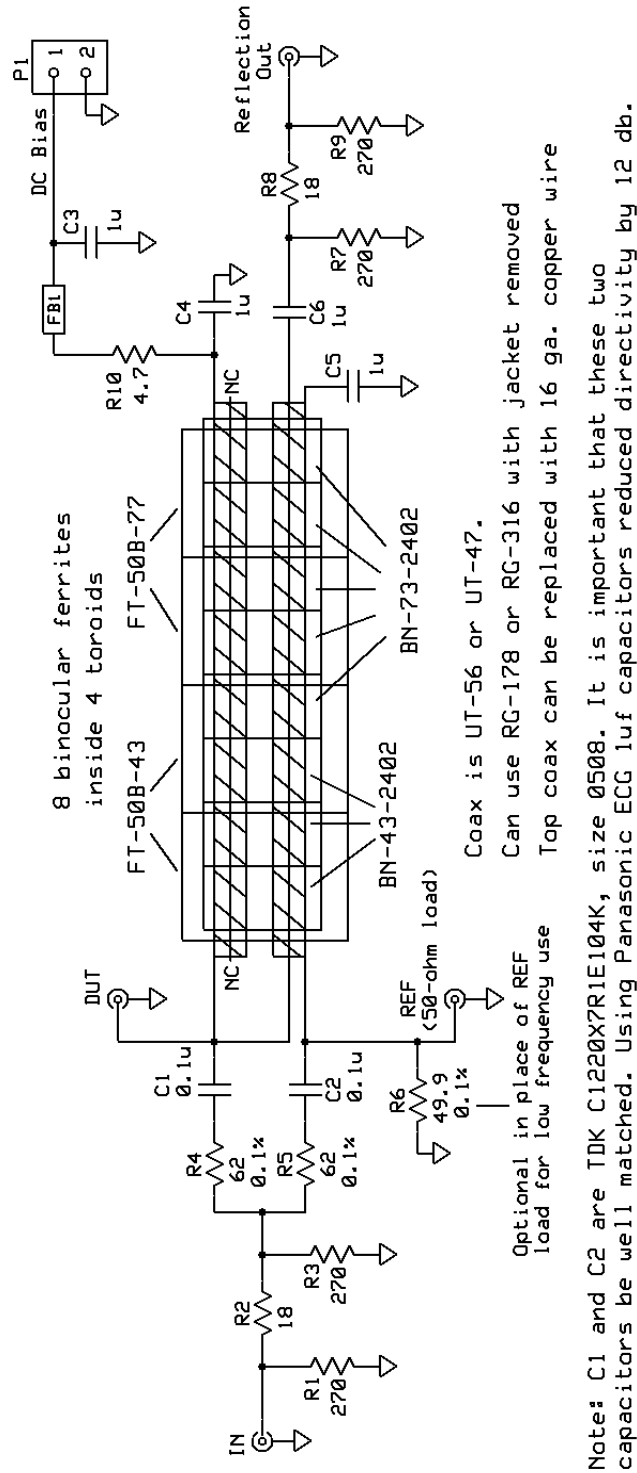

**Appendix B—Photo of the “Parallel Line” Bridge**

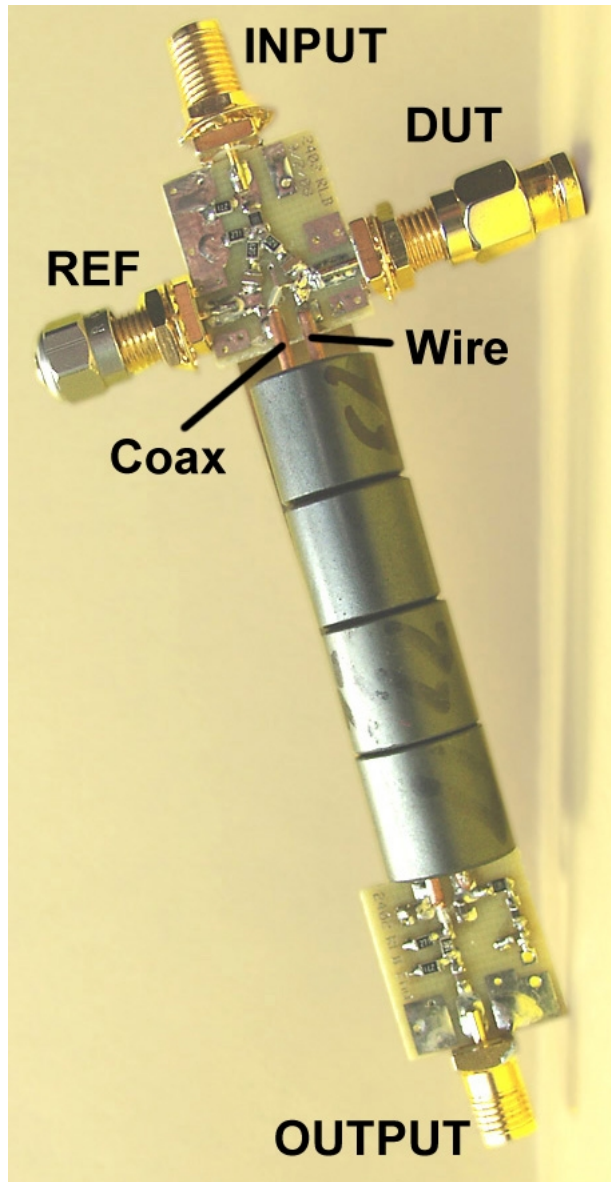

# Appendix C—Schematic of the Active Bridge

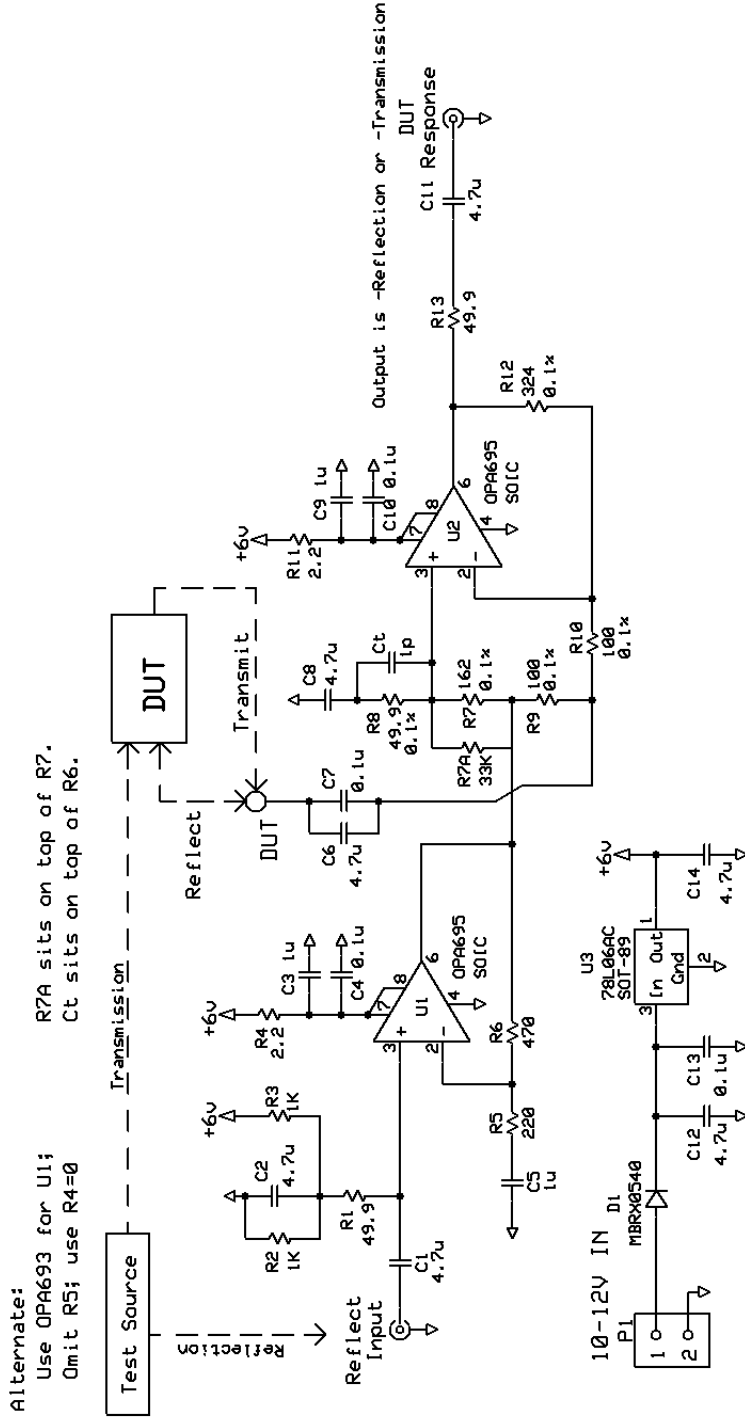

**Appendix D—Photo of the Active Bridge**

